

DATA SHEET

S5LPJ2999

Correctal® T60/0.73D
telecentric lens
with c-mount

no picture available

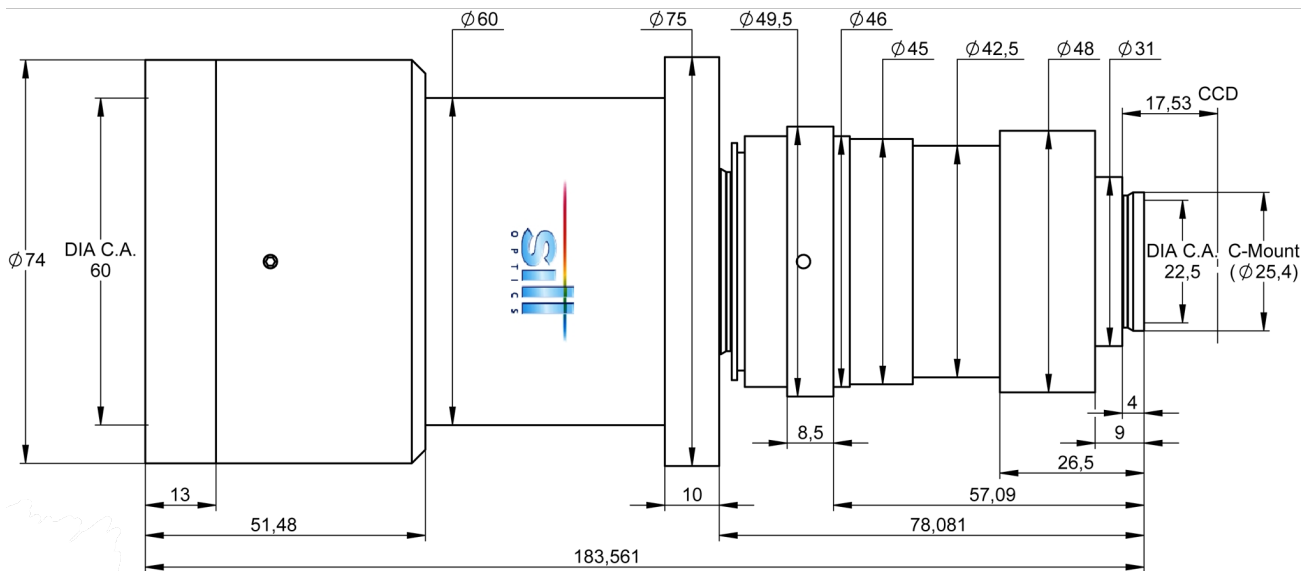

outline drawing

other adapter on special request

S5LPJ2999

Correctal® T60/0.73D telecentric lens with c-mount

Specifications	
part number	S5LPJ2999
magnification (+/-5%)	0.732
working distance [mm] (+/-2%)	92.0
max. object size [mm] at a chip size of [mm]	6.5 x 4.9 4.8 x 3.6 (1/3")
distorsion [%]	<0.05
max. object size [mm] at a chip size of [mm]	8.7 x 6.5 6.4 x 4.8 (1/2")
distorsion [%]	0.07
max. object size [mm] at a chip size of [mm]	12.0 x 9.0 8.8 x 6.6 (2/3")
distorsion [%]	0.11
max. object size [mm] at a chip size of [mm]	17.4 x 13.1 12.8 x 9.6 (1")
distorsion [%]	0.15
numerical aperture	0.034
max. outside-Ø [mm]	74.0 / 75.0
length [mm] (+/-2%)	179.6
weight [kg]	not yet weighed

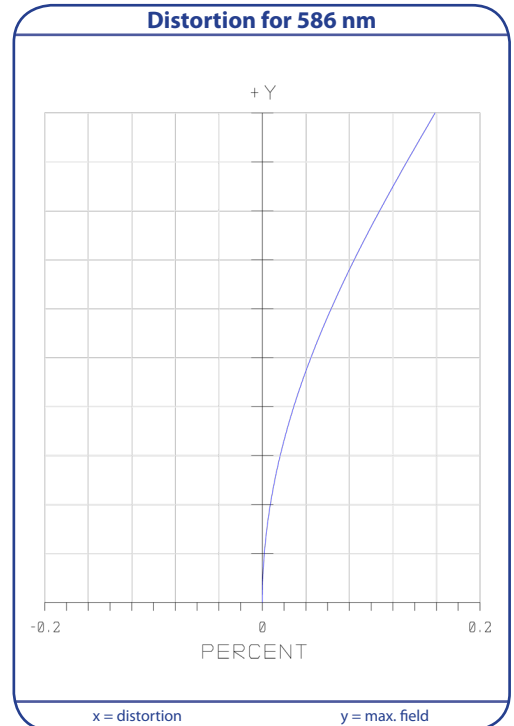

T.. Tangential

MTF for various object heights at 586nm

S.. Sagittal

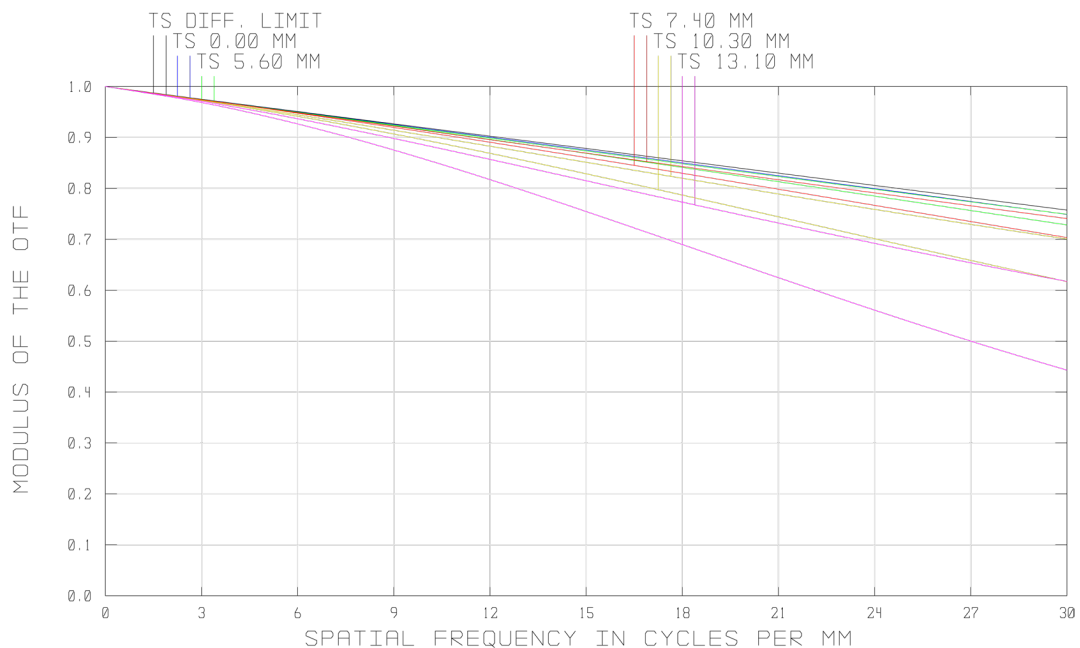

also available with coaxial illumination (S5LPL2999) and coaxial LED illumination (S5LPL2999/LED)