

## DATA SHEET

### S5LPJ7290

**SillVision T160/0.055**  
**double-sided telecentric**  
**lens with c-mount**

no picture available

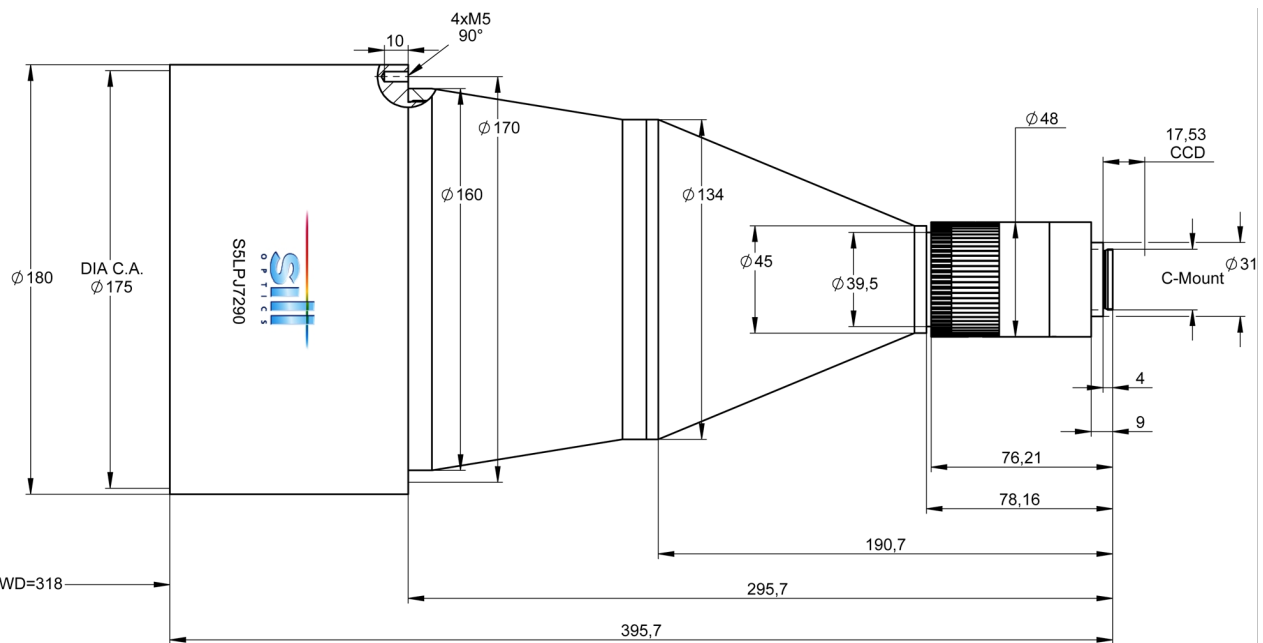

outline drawing

other adapter on special request

## S5LPJ7290

### SillVision T160/0.055 double-sided telecentric lens with c-mount

Specifications	
part number	S5LPJ7290
magnification (+/-5%)	0.055
working distance [mm] (+/-2%)	318.0
max. object size [mm] at a chip size of [mm]	65.4 x 50.9 3.6 x 2.8 (1/4")
distorsion [%]	0.4
max. object size [mm] at a chip size of [mm]	87.2 x 65.4 4.8 x 3.6 (1/3")
distorsion [%]	0.5
max. object size [mm] at a chip size of [mm]	116.3 x 87.2 6.4 x 4.8 (1/2")
distorsion [%]	0.5
max. object size [mm] at a chip size of [mm]	(130.9 x 81.2) 7.2 x 5.3 (1/1.8")
distorsion [%]	(0.5)
numerical aperture	0.006
max. outside-Ø [mm]	180.0
length [mm] (+/-2%)	391.7
weight [kg]	not yet weighed

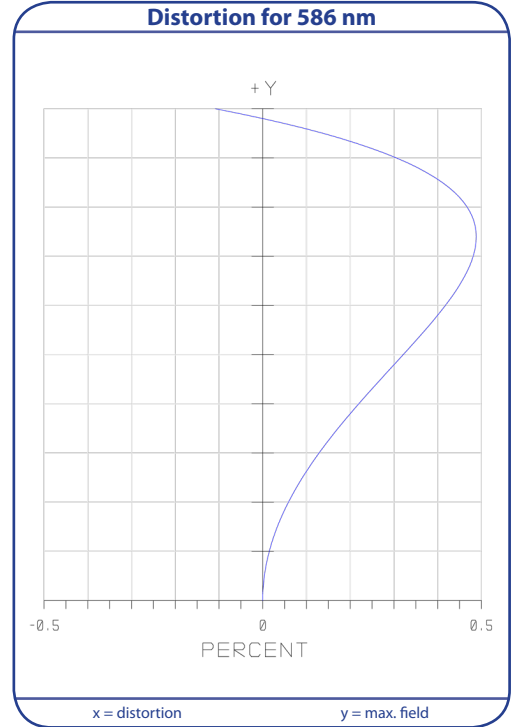

T.. Tangential

### MTF for various object heights at 586nm

S.. Sagittal

