

DATA SHEET

S5LPL5725/LED

Correctal® TA57/0.25
telecentric lens
with c-mount

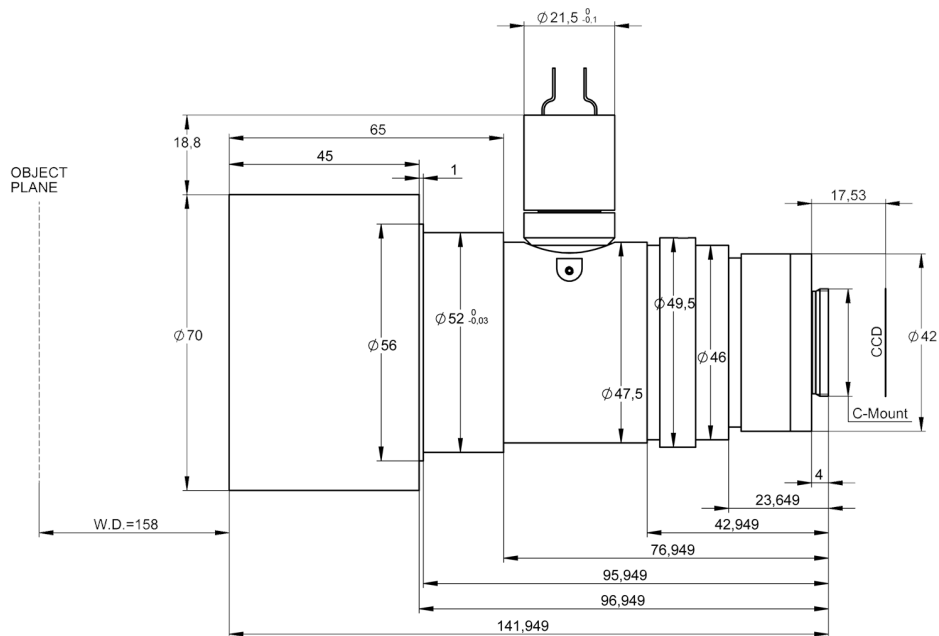

outline drawing

other adapter on special request

S5LPL5725/LED

Correctal® TA57/0.25 telecentric lens with c-mount

Specifications	
part number	S5LPL5725/LED
magnification (+/-5%)	0.256
working distance [mm] (+/-2%)	158.0
max. object size [mm] at a chip size of [mm] distorsion [%]	18.7 x 14.0 4.8 x 3.6 (1/3") 0.05
max. object size [mm] at a chip size of [mm] distorsion [%]	24.9 x 18.7 6.4 x 4.8 (1/2") 0.1
max. object size [mm] at a chip size of [mm] distorsion [%]	28.1 x 20.7 7.2 x 5.3 (1/1.8") 0.12
max. object size [mm] at a chip size of [mm] distorsion [%]	34.3 x 25.7 8.8 x 6.6 (2/3") 0.12
numerical aperture	0.03
max. outside-Ø [mm]	70.0
length [mm] (+/-2%)	138.0
weight [kg]	not yet weighed

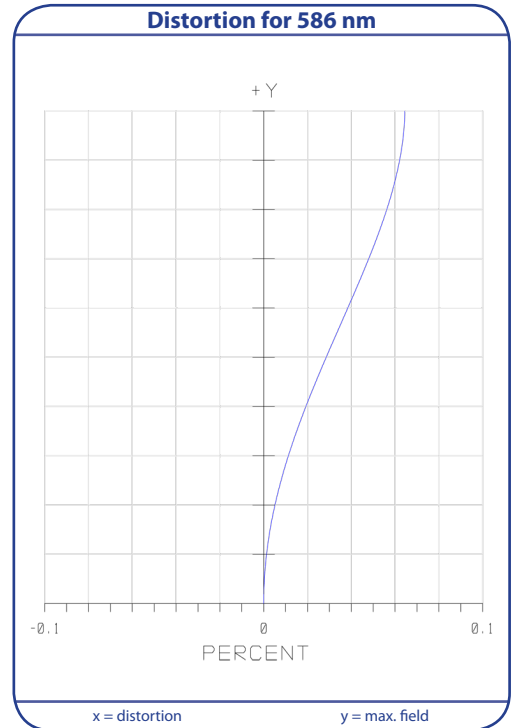

T.. Tangential

MTF for various object heights at 586nm

S.. Sagittal

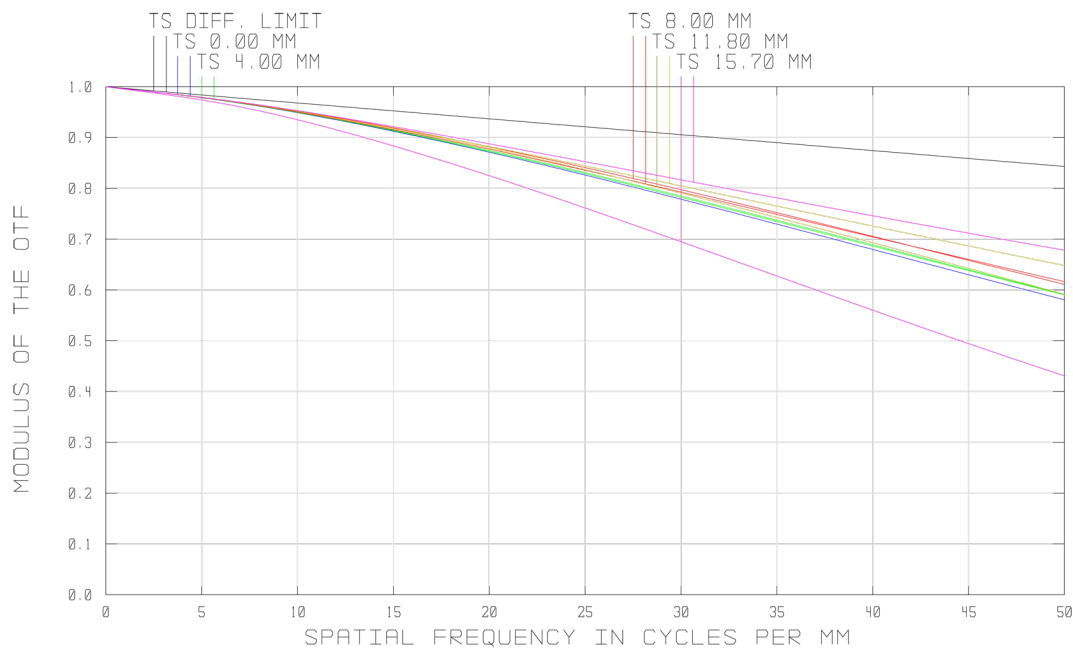

LED: 300 mA, 2.95 V