

DATA SHEET



S5LPL2298/LED Correctal® TA60/0.24

- telecentric lens
- with c-mount
- with variable iris
- with integrated coaxial illumination

electrical specifications for S5LPLxxxx/LED, mechanical interface for S5LPLxxxx/CCS and optimum illumination settings for both see [product family data sheet attached](#)



illustration only

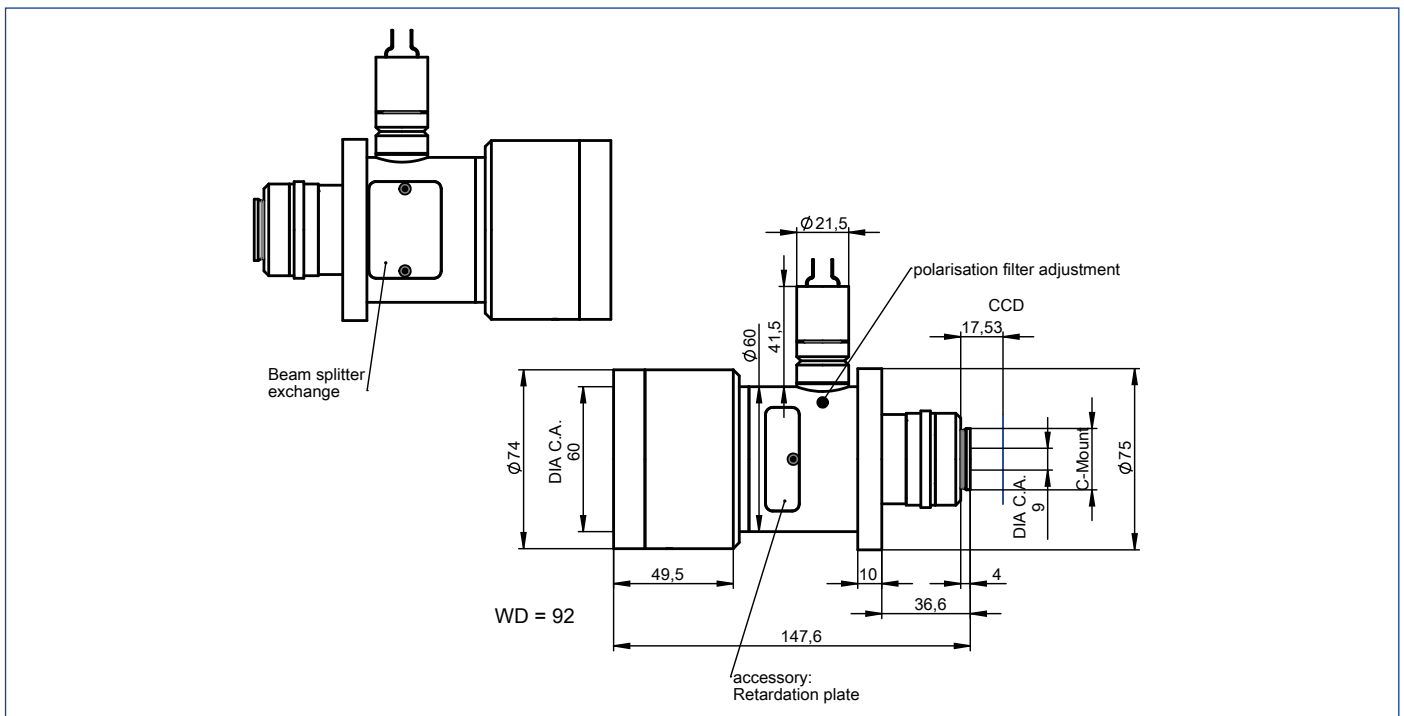

outline drawing

DATA SHEET



specifications

article number	SSLPL2298/LED
design wavelength [nm]	400-700
magnification (+/-5%)	0.244
working distance [mm] (+/-2%)	92.0
object size [mm]	13.1 x 9.8
at a chip size of [mm]	3.2 x 2.4 (1/4")
distortion [%]	0.01
object size [mm]	19.6 x 14.7
at a chip size of [mm]	4.8 x 3.6 (1/3")
distortion [%]	0.02
object size [mm]	26.2 x 19.6
at a chip size of [mm]	6.4 x 4.8 (1/2")
distortion [%]	0.02
max. telecentricity error [°]	< 0.01
numerical aperture	0.020
weight [kg]	not yet weighed
flange back distance [mm]	17.53
accessory	S5SET1150, S0SET9125/017, S5SET0020, S5SET5016

Distortion for 586 nm

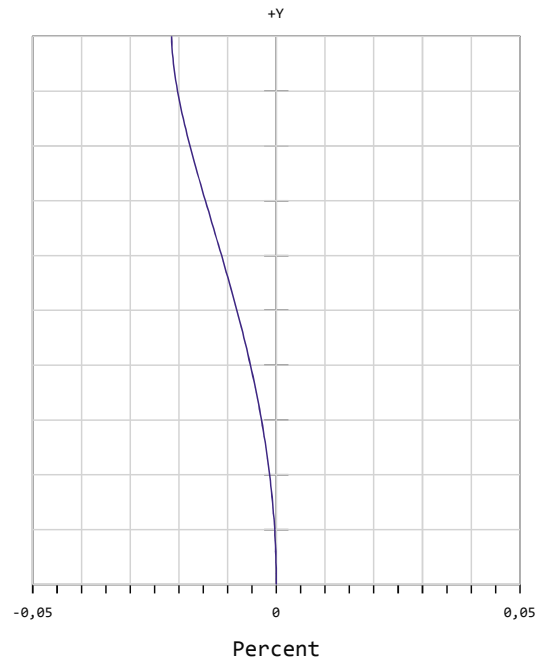

x = distortion

y = max. field

MTF for various object heights at 586 nm

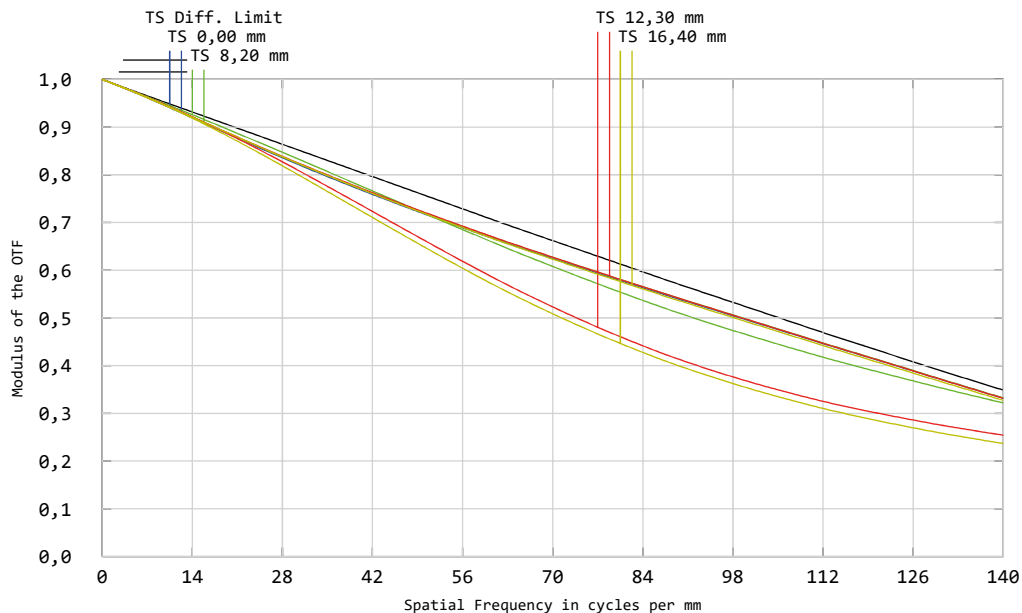

T. tangential

S. sagittal

graphs and data given by design.

Sill Optics
GmbH & Co. KG
Johann-Höllfritsch-Straße 13
D-90530 Wendelstein

Copyright © Sill Optics GmbH & Co. KG
All rights reserved.
Issue A
Published: 8.08.2018

Tel.: +49 (0) 9129 9023 0
Fax: +49 (0) 9129 9023 23
E-mail: info@silloptics.de
Web: www.silloptics.de

All information contained in this data sheet is for information purposes only and is not binding. The content is subject to change at any time without notification, all information without guarantee. We reserve the right to make constructional changes in the course of product improvement.