

PORTFOLIO

CATALOGUE 2026





Sill
OPTICS
S4LFT0260/159

YOUR DEMAND - OUR SOLUTION

NEW „AVAILABLE FROM STOCK“ PROGRAM	4
CUSTOM OPTICAL SOLUTION	5-6

PORTFOLIO LASER OPTICS

F-THETA LENSES	7-9
BEAM EXPANDERS	10-12
ASPHERES	13
FOCUSING ELEMENTS	14
TRAPPED ION LENSES	15
TECHNICAL GUIDE	16-19

PORTFOLIO IMAGING OPTICS

TELECENTRIC IMAGING LENSES	20-23
SPECIAL LENSES	24
LED CONDENSERS & ACCESSORY	25
TECHNICAL GUIDE	26-29
NOTES	30-31

New “Available from Stock” Program Faster Delivery for Our Customers

To provide our customers with even more flexibility and planning reliability, Sill Optics is expanding its service offering. In addition to our comprehensive portfolio of high-quality laser and imaging optics, we now offer selected products directly available from stock. This allows us to reduce delivery times for standard components to approximately two weeks – a significant advantage when projects need to start quickly or when fast replacements are required.



The stock-ready items include optics from particularly high-demand product categories used in many industrial applications. With this new service, we are responding to our customers’ growing need for short response times and dependable availability, without compromising on quality or performance.

In our tabular product overview, all items available from stock are clearly marked with a special icon, making it easy to identify immediately which products can be delivered at short notice. This supports fast decision-making and efficient project planning.

Naturally, the shortened delivery time applies to standard order quantities, ensuring that stock levels remain stable and economically reasonable. For larger volumes or customized designs, our team from sales and project management remains at your disposal to realize tailored optical solutions.

With our new stock availability program, we offer our customers added value through flexibility, speed, and premium optical quality – strengthening Sill Optics’ position as a reliable and forward-thinking partner in the photonics industry.



CUSTOM OPTICAL SOLUTIONS

BENEFIT FROM OUR EXPERTISE



SILL OPTICS – CUSTOM OPTICAL SOLUTIONS

Sill Optics has been a trusted partner for custom optical solutions for decades, designing and manufacturing both high-performance laser optics and precision imaging lenses. Thanks to our extensive expertise, we have delivered a wide range of custom optical designs and specialized mechanical layouts for numerous industries.

One of Sill Optics' greatest strengths is our ability to find technical solutions for two completely different customer requirements. Laser optics must direct and focus laser beams with a power of up to several hundred kilowatts with minimal losses, while imaging optics must be precise enough to ensure that even individual photons reliably find their way to the sensor surfaces. Understanding both extremes enables us to develop optical-mechanical systems that push the boundaries of performance. Sill Optics combines expertise from both areas of photonics to develop robust optomechanical systems that can simultaneously monitor machining processes and withstand the demanding conditions found in industrial environments and defense and aerospace applications.

Our close internal collaboration, extensive in-house manufacturing capabilities, and high-quality series production form the basis for this expertise. This integrated workflow enables us to build prototypes in the shortest possible time while ensuring maximum precision, consistency, and reliability.

In both laser optics and imaging optics, we serve a wide range of markets, including laser material processing, quantum technology, e-mobility, medical technology, mechanical engineering, the semiconductor & display industry, additive manufacturing, metrology, and defense & aerospace.

We pride ourselves on delivering customized optical solutions that precisely meet the functional, environmental, and performance requirements of each individual application—no matter how specialized or demanding.



LASER MATERIAL PROCESSING



PROCESS MONITORING



QUANTUM TECHNOLOGY



E-MOBILITY



MEDICAL TECHNOLOGY



MECHANICAL ENGINEERING



SEMICONDUCTOR & DISPLAY



ADDITIVE MANUFACTURING



METROLOGY



DEFENSE & AEROSPACE

WHEN STARTING A PROJECT?

Sill Optics is able to grow with its customers and projects. Even for quantities as small as one, we are ready to develop a technically optimized solution for the customer. The ideal number of items will vary depending on the size, number of elements, and complexity of the system. A very attractive price-performance ratio typically results for quantities in the range of 50 to 100 pieces. However, Sill Optics' production capacity is well-suited for up to thousands pieces per year.

WHY SILL OPTICS?

- Development of specification sheets closely aligned with design and production capabilities
- Direct contact with optical designers
- Short distances between design, development and production
- Quick turnaround for prototypes
- High quality in series production
- Customized quality assurance based on individual needs

SPECIFICATIONS FOR LASER OPTICS:

- General information about the laser source: wavelength, pulse duration, pulse energy, beam quality
- Focusing system: focal length, spot diameter, entrance beam diameter
- Lenses of Scanner applications: focal length, spot diameter, entrance beam diameter, mirror distances, scanner type, telecentricity, scan field size
- Beam expander: entrance beam diameter, magnification, fixed or flexible or motorization
- Trapped Ion lens: NA, vacuum window data (thickness, material, position), scan field size

SPECIFICATIONS IMAGING OPTICS:

- Aperture
- Field size (FOV, sensor size)
- Bandwidth (UV, VIS, NIR, SWIR, LWIR)
- Space constraints (total track, working distance, maximum length, maximum diameter, mounting)
- Camera specifications (sensor dimensions, pixel size, resolution, camera thread, back flange distance, maximum chief ray angle, color)
- Performance requirements (Strehl ratio, MTF, edge spread function, distortion, color correction)

WORKFLOW THROUGH OUR CUSTOM DESIGN PROCESS

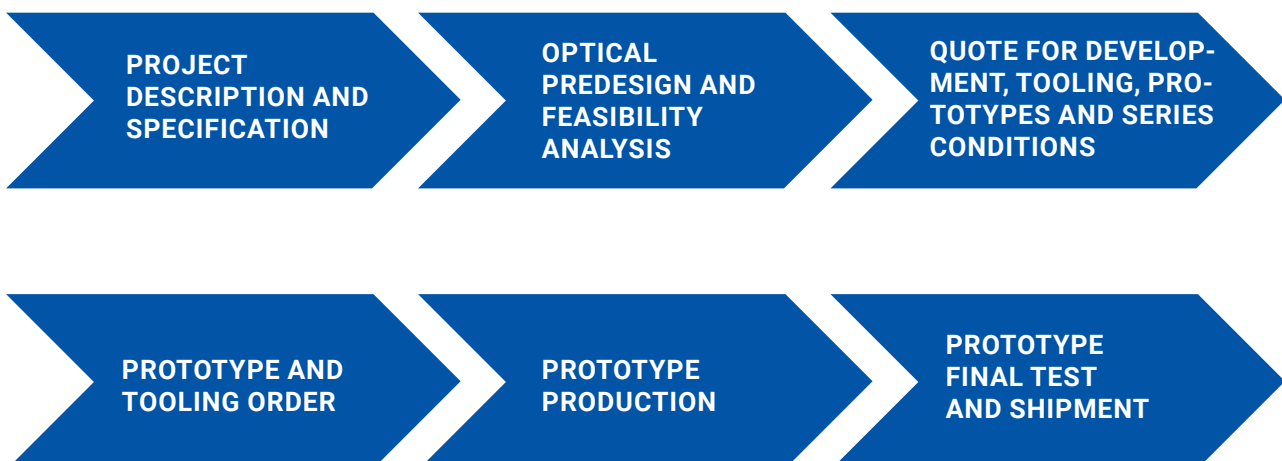

PORTFOLIO LASER OPTICS

F-THETA LENSES



Sill Optics has been manufacturing high-quality laser optics for almost 40 years. These lenses are specifically designed for laser material processing applications for industrial mechanical engineering.

They are specially designed for applications in CE, automotive, semiconductor, additive or solar cell manufacturing. In addition to medical and biotech applications (confocal microscopy, ophthalmology) and science and research. The design and the quality of the optical components play a key role in the lens performance.

GLASS OPTICS

PART NUMBER	FOCAL LENGTH [mm]	SCAN AREA [mm x mm]	FOCUS SIZE (1/e ²) [μm]	MAX. BEAM-Ø [mm]	MAX. TELE-CENTRICITY ERROR [°]	WORKING DISTANCE [mm]	SP/USP*	ACHROMATIC
1064 nm								
S4LFT0080-126	80	39 x 39	6.5	25	3.8	79.4	no	no
 S4LFT0163-126A	163	107 x 107	26.4	12	15	181.2	no	no
S4LFT0253-126	254	160 x 160	35.2	14	16.7	284.9	no	no
S4LFT1254-126	254	160 x 160	41.4	12	14.9	306.5	no	no
S4LFT3254-126	254	115 x 115	16.6	30	8.5	297.0	no	no
S4LFT0350-126	350	212 x 212	56.3	12	16	412.2	no	no
S4LFT0420-126	420	242 x 242	27.7	30	14.8	480.9	no	no
S4LFT0508-126	508	325 x 325	55.6	20	16.3	651.4	no	no
S4LFT0635-126	635	370 x 370	51.3	25	16.3	732.8	no	no
532+1064 nm								
S4LFT1163-081	163	102 x 102	13.3 / 20.0	12	12.7	159.0	no	yes
S4LFT8254-081	254	180 x 180	16.6 / 33.0	15	19.7	211.6	no	yes
515-589 nm								
S4LFT7012-292	100	35 x 35	9.4	10	1.3	101.4	yes	yes
532 nm								
S4LFT5100-121	100	69 x 69	9.8	10	2.4	126.7	no	no
S4LFT0300-121	300	200 x 200	19.4	14	15.8	324.1	no	no





Besides our portfolio and customized optics, we also offer a variety of F-Theta lenses and Beam Expanders from our former portfolio with outstanding specifications upon request. This also includes lenses for different lens markets, applications and specifications.

- **MORE WAVELENGTHS**
- **MORE FOCAL LENGTHS**
- **MORE MAGNIFICATIONS**

*usable for SP=Short Pulse, USP=Ultra Short Pulse

In case of deviations from the portfolio and delivery times, please contact our Customer Care Team.

FUSED SILICA OPTICS

PART NUMBER	FOCAL LENGTH [mm]	SCAN AREA [mm x mm]	FOCUS SIZE (1/e ²) [μm]	MAX. BEAM-Ø [mm]	MAX. TELECENTRICITY ERROR [°]	WORKING DISTANCE [mm]	SP/USP*
1030-1080 nm							
S4LFT4147-328	48	7 x 7	6.3	15	2.1	61.1	yes
S4LFT4065-328	65	15 x 15	9.4	15	2	83.1	yes
S4LFT0710-328	100	60 x 60	39.1	5	11.5	120.7	yes
 S4LFT4010-328	100	35 x 35	19.5	10	1.3	129.8	yes
S4LFT4127-328	125	50 x 50	13.6	15	1.5	157.6	yes
S4LFT0763-328	163	100 x 100	45.6	7	14.6	194.1	yes
 S4LFT3162-328	163	90 x 90	21.2	15	5.6	201.5	yes
S4LFT3167-328	163	100 x 100	32.6	10	11.6	200.7	yes
S4LFT0725-328	254	140 x 140	61.5	8	16.2	282.8	yes
S4LFT3250-328	254	160 x 160	33.2	15	10.7	321.3	yes
S4LFT1330-328	330	215 x 215	33.3	20	23.5	203.4	yes
S4LFT1420-328	420	280 x 280	58.5	14	17.3	499.2	yes
S4LFT2420-328	420	255 x 255	43.6	20	15.3	510	yes
S4LFT5430-328	430	250 x 250	30.0	30	11.6	538	yes
 S4LFT1655-328	650	410 x 410	63.3	20	22.5	581.6	yes
S4LFT0910-328	910	500 x 500	65.8	30	16.2	1048.8	yes
515-532 nm							
S4LFT4148-292	48	6 x 6	3.2	15	1.8	60	yes
S4LFT4066-292	65	15 x 15	4.8	15	1.5	85.8	yes
 S4LFT4010-292	100	35 x 35	9.8	10	1.5	130.2	yes
S4LFT4126-292	125	53 x 53	12	10	1.6	167	yes
 S4LFT3161-292	163	90 x 90	15.4	10	4.8	219	yes
S4LFT4262-292	163	65 x 65	12.7	12	1.7	195.4	yes
S4LFT1330-292	330	212 x 212	24.3	14	20.3	279	yes
S4LFT5650-292	650	410 x 410	31.8	20	22.7	569.9	yes
420-480 nm							
S4LFT4125-373	125	45 x 45	6.1	20	1.6	160.2	yes
S4LFT3170-373	168	75 x 75	7.6	20	3.2	228.3	yes
S4LFT3250-373	241	115 x 115	10	20	7.4	304.8	yes
S4LFT1330-373	330	180 x 180	10.7	20	11.1	268.2	yes

PORTFOLIO LASER OPTICS

F-THETA LENSES



FUSED SILICA OPTICS

PART NUMBER	FOCAL LENGTH [mm]	SCAN AREA [mm x mm]	FOCUS SIZE (1/e ²) [μm]	MAX. BEAM-Ø [mm]	MAX. TELECENTRICITY ERROR [°]	WORKING DISTANCE [mm]	SP/USP*
343-355 nm							
S4LFT4149-075	48	6 x 6	2.1	15	2.1	69.3	yes
S4LFT4067-075	65	15 x 15	3.1	15	1.8	81.7	yes
S4LFT4010-075	100	35 x 35	6.5	10	1.2	132	yes
S4LFT4125-075	125	53 x 53	8	10	1.1	156.9	yes
S4LFT3170-075	163	90 x 90	11.4	10	4.3	221.7	yes
S4LFT4262-075	163	65 x 65	10.5	10	2	193.7	yes
S4LFT1330-075	330	210 x 210	15.4	14	21	260.5	yes
S4LFT3340-075	340	205 x 205	17.0	14	0.85	479.5	yes
257-266 nm							
S4LFT4068-199	65	20 x 20	2.5	15	1.3	85.6	yes
S4LFT3170-199	154	85 x 85	7.7	10	3.8	208.1	yes
S4LFT4263-199	163	70 x 70	9.2	10	2.6	218.4	yes











Sill Optics has been manufacturing high-quality laser optics more than 40 years. These lenses are specifically designed for laser material processing applications of industrial mechanical engineering. They are specially designed for applications in quantum technology, e-mobility, medical and biotechnology, the semiconductor & display industry, additive manufacturing, metrology, and defense & aerospace.

The design and the quality of the optical components play a key role in the lens performance.

Many of our beam expanders can also be used in reverse to increase the divergence of the beam, for example. If you have any questions about these effects and other special features, please contact our technical support team.

ZOOM BEAM EXPANDERS

PART NUMBER	MAGNIFICATION	CLEAR INPUT APERTURE [mm]	CLEAR OUTPUT APERTURE [mm]	LENGTH [mm]	THREAD
9300-10600 nm					
S6EXZ9313-684	1-3x	28.5	45.0	150.0	M55x1
S6EXZ9313-681	1-3x	28.5	45.0	150.0	M55x1
1030-1080 nm					
 S6EXZ5310-328	1-3x	10.5	20.0	85.2	C-Mount
 S6EXZ5311-328	1-3x	10.5	20.0	85.2	M30x1
 S6EXZ5076-328	1-8x	10.3	31.0	162.0	C-Mount
515-532 nm					
S6EXZ5310-292	1-3x	10.5	20.0	85.2	C-Mount
 S6EXZ5311-292	1-3x	10.5	20.0	85.2	M30x1
 S6EXZ5076-292	1-8x	10.3	31.0	162.0	C-Mount
355 nm					
S6EXZ5310-075	1-3x	10.5	20.0	85.2	C-Mount
 S6EXZ5311-075	1-3x	10.5	20.0	85.2	M30x1
 S6EXZ5075-075	1-8x	10.3	31.0	162.0	C-Mount
343-355 nm					
S6EXZ0940-574	0.9-4x	16.0	28.0	191.0	M30x1
 S6EXZ5310-574	1-3x	10.5	20.0	85.2	C-Mount
 S6EXZ5311-574	1-3x	10.5	20.0	85.2	M30x1
S6EXZ5075-574	1-8x	10.3	31.0	162.0	C-Mount
257-266 nm					
S6EXZ5075-199	1-8x	10.3	31.0	162.0	C-Mount

MOTORIZED BEAM EXPANDER

PART NUMBER	MAGNIFICATION	CLEAR INPUT APERTURE [mm]	CLEAR OUTPUT APERTURE [mm]	LENGTH [mm]	THREAD
343-355 nm					
S6EZM0940-574	0.9-4x	12.0	28.0	200.0	M30x1

In case of deviations from the portfolio and delivery times, please contact our Customer Care Team.

PORTFOLIO LASER OPTICS

BEAM EXPANDERS



FIX MAGNIFICATION BEAM EXPANDERS

PART NUMBER	MAGNIFICATION	CLEAR INPUT APERTURE [mm]	CLEAR OUTPUT APERTURE [mm]	LENGTH [mm]	THREAD
1030-1080 nm					
S6EXK0005-328	0.5	12.0	12.0	44.7	M30x1
S6EXK0008-328	0.8	12.0	12.0	44.7	M30x1
S6EXK0010-328	1.0	12.0	14.0	44.7	M30x1
S6EXK0012-328	1.2	12.0	26.0	44.7	M30x1
S6EXK0015-328	1.5	12.0	26.0	44.7	M30x1
S6EXK0020-328	2.0	12.0	26.0	44.7	M30x1
S6EXK0025-328	2.5	11.0	26.0	44.7	M30x1
S6EXK0030-328	3.0	8.0	26.0	44.7	M30x1
S6EXK0035-328	3.5	8.0	20.0	44.7	M30x1
S6EXK0040-328	4.0	8.0	20.0	44.7	M30x1
515-532 nm					
S6EXK0005-292	0.5	12.0	12.0	44.7	M30x1
S6EXK0008-292	0.8	12.0	12.0	44.7	M30x1
S6EXK0010-292	1.0	12.0	14.0	44.7	M30x1
S6EXK0012-292	1.2	12.0	26.0	44.7	M30x1
S6EXK0015-292	1.5	12.0	26.0	44.7	M30x1
S6EXK0020-292	2.0	12.0	26.0	44.7	M30x1
S6EXK0025-292	2.5	11.0	26.0	44.7	M30x1
S6EXK0030-292	3.0	8.0	26.0	44.7	M30x1
S6EXK0035-292	3.5	8.0	20.0	44.7	M30x1
S6EXK0040-292	4.0	8.0	20.0	44.7	M30x1
355 nm					
S6EXK0008-075	0.8	12.0	12.0	44.7	M30x1
S6EXK0012-075	1.2	12.0	26.0	44.7	M30x1
S6EXK0015-075	1.5	12.0	26.0	44.7	M30x1
S6EXK0020-075	2.0	12.0	26.0	44.7	M30x1
S6EXK0025-075	2.5	11.0	26.0	44.7	M30x1
S6EXK0030-075	3.0	8.0	26.0	44.7	M30x1
S6EXK0035-075	3.5	8.0	20.0	44.7	M30x1
S6EXK0040-075	4.0	8.0	20.0	44.7	M30x1
343-355 nm					
S6EXK0008-574	0.8	12.0	12.0	44.7	M30x1
S6EXK0010-574	1.0	12.0	14.0	44.7	M30x1
S6EXK0012-574	1.2	12.0	26.0	44.7	M30x1
S6EXK0015-574	1.5	12.0	26.0	44.7	M30x1
S6EXK0020-574	2.0	12.0	26.0	44.7	M30x1
S6EXK0025-574	2.5	11.0	26.0	44.7	M30x1
S6EXK0030-574	3.0	8.0	26.0	44.7	M30x1
S6EXK0035-574	3.5	8.0	20.0	44.7	M30x1
S6EXK0040-574	4.0	8.0	20.0	44.7	M30x1



FIX MAGNIFICATION BEAM EXPANDERS

PART NUMBER	MAGNIFICATION	CLEAR INPUT APERTURE [mm]	CLEAR OUTPUT APERTURE [mm]	LENGTH [mm]	THREAD
1030-1080 nm					
S6EXP0005-328	0.5	14.0	31.0	85.0	M30x1
S6EXP0008-328	0.8	14.0	20.0	85.0	M30x1
S6EXP0012-328	1.2	14.0	28.0	85.0	M30x1
S6EXP0015-328	1.5	8.0	31.0	85.0	M30x1
S6EXP0020-328	2.0	8.0	31.0	85.0	M30x1
S6EXP0025-328	2.5	8.0	31.0	85.0	M30x1
S6EXP0030-328	3.0	8.0	31.0	85.0	M30x1
S6EXP0040-328	4.0	8.0	31.0	85.0	M30x1
S6EXP0050-328	5.0	8.0	31.0	85.0	M30x1
515-532 nm					
S6EXP0005-292	0.5	14.0	31.0	85.0	M30x1
S6EXP0008-292	0.8	14.0	20.0	85.0	M30x1
S6EXP0015-292	1.5	8.0	31.0	85.0	M30x1
S6EXP0020-292	2.0	8.0	31.0	85.0	M30x1
S6EXP0025-292	2.5	8.0	31.0	85.0	M30x1
S6EXP0030-292	3.0	8.0	31.0	85.0	M30x1
S6EXP0040-292	4.0	8.0	31.0	85.0	M30x1
S6EXP0050-292	5.0	8.0	31.0	85.0	M30x1
355 nm					
S6EXP0015-075	1.5	8.0	31.0	85.0	M30x1
S6EXP0020-075	2.0	8.0	31.0	85.0	M30x1
S6EXP0025-075	2.5	8.0	31.0	85.0	M30x1
S6EXP0030-075	3.0	8.0	31.0	85.0	M30x1
S6EXP0040-075	4.0	8.0	31.0	85.0	M30x1
S6EXP0050-075	5.0	8.0	31.0	85.0	M30x1
343-355 nm					
S6EXP0015-574	1.5	8.0	31.0	85.0	M30x1
S6EXP0020-574	2.0	8.0	31.0	85.0	M30x1
S6EXP0025-574	2.5	8.0	31.0	85.0	M30x1
S6EXP0030-574	3.0	8.0	31.0	85.0	M30x1
S6EXP0040-574	4.0	8.0	31.0	85.0	M30x1
S6EXP0050-574	5.0	8.0	31.0	85.0	M30x1
257-266 nm					
S6EXP0015-199	1.5	8.0	31.0	85.0	M30x1
S6EXP0020-199	2.0	8.0	31.0	85.0	M30x1
S6EXP0030-199	3.0	8.0	31.0	85.0	M30x1
S6EXP0040-199	4.0	8.0	31.0	85.0	M30x1
S6EXP0050-199	5.0	8.0	31.0	85.0	M30x1

PORTFOLIO LASER OPTICS

ASPHERES



ASPHERES

The use of aspheric lenses in optical systems is increasing. Aspheric lenses enable an enhancement of resolution especially for optical systems with a high numerical aperture. The aspheric deviation of the high end series is smaller than 0.05 μm RMSi.

Aspheres offer the great advantage to accomplish monochromatic imaging tasks with one optical element where multiple lens elements would otherwise be needed. Main advantages of aspheres are less spherical aberrations, less weight, increased transmission and no internal ghosts.

PART NUMBER	FOCAL LENGTH [mm]	LENS-Ø [mm]	CENTER THICKNESS [mm]	WORKING DISTANCE [mm]
1064 nm				
S1ADX0220-328	20	25.0	13.2	13.3
S1ADX0230-328	30	30.0	16.0	20.9
S1ADX0240-328	40	30.0	15.0	31.3
S1ADX0250-328	50	30.0	13.7	42.1
S1ADX0260-328	60	30.0	11.3	53.5
S1ADX0370-328	72	38.1	11.0	63.6
S1ADX0380-328	80	38.1	12.0	73.1
S1ADX0310-328	100	38.1	11.0	93.7
S1ADX0312-328	120	38.1	10.3	114.0
S1ADX0316-328	150	30.0	9.6	144.4
S1ADX0315-328	150	38.1	9.6	144.4
S1ADX0320-328	200	38.1	8.9	194.8
S1ADX0325-328	250	38.1	8.9	245.2
S1ADX0330-328	300	30.0	9.0	294.7
S1ADX0540-328	400	52.0	8.0	395.2



In case of deviations from the portfolio and delivery times, please contact our Customer Care Team.

LENS SYSTEMS

Multi-element lens systems minimize the imaging errors of single lenses and provide precision focusing for non-scanning applications.

MULTI-ELEMENT LENS SYSTEMS

PART NUMBER	FOCAL LENGTH [mm]	FOCUS SIZE $1/e^2$ [μm]	HOUSING-Ø [mm]	LENGTH [mm]	WORKING DISTANCE [mm]
532 nm					
S6ASS2020-292	25	2.4	25.0	13.5	19.3
S6ASS2060-292	62	3.0	40.0	32.0	47.9
S6ASS5300-292	100	5.4	41.0	16.0	86.7
S6ASS6151-292	150	7.2	56.0	20.0	135.0
S6ASS6200-292	200	6.6	54.0	15.0	188.5
355 nm					
S6ASS2020-075	25	1.6	25.0	17.0	17.9
S6ASS2060-075	60	2.8	40.0	30.0	46.5
S6ASS5120-075	114	5.6	48.0	20.0	104.4
266 nm					
S6ASS2020-199	24	1.4	25.0	17.0	17.1
S6ASS2060-199	57	2.2	40.0	30.0	43.9
S6ASS5120-199	109	4.6	48.0	20.0	99.1

Besides our portfolio and customized optics, we also offer a variety of F-Theta lenses and Beam Expanders from our former portfolio with outstanding specifications upon request. This also includes lenses for different lens markets, applications and specifications.

- **MORE WAVELENGTHS**
- **MORE FOCAL LENGTHS**
- **MORE MAGNIFICATIONS**



In case of deviations from the portfolio and delivery times, please contact our Customer Care Team.

PORTFOLIO LASER OPTICS

TRAPPED ION LENSES



TRAPPED ION LENSES

Trapped (cold) ions are a research topic with increasing interest over the last few years because of their possibility to store Qubits (quantum bits) and the related use for quantum computers. To make the qubits usable under certain conditions, we must observe and study their behaviour in detailed experiments first.

Sill Optics has designed lenses both, for just observation and observation combined with laser focusing for these experiments. Those lenses are exceptional for their high NA and adjustment to specific wavelengths (UV to IR). As the vacuum cryostats differ in dimension (e.g. the window thickness) every lens has to be designed specifically for the existing conditions.

PART NUMBER	WAVE-LENGTH 1 [nm]	WAVE-LENGTH 2 [nm]	MATERIAL	FOCUS LENGTH [mm]	NA	MAX. FOV [mm]	MAGNIFICATION @ WAVE-LENGTH 1	MAGNIFICATION @ WAVE-LENGTH 2	THICKNESS WINDOW	MATERIAL WINDOW	WORKING DISTANCE [mm]
S6ASS2243-126	1064	-	optical glass	40.5	0.4	0.71	infinity	-	6.0	fused silica	50.7
S6ASS2242-081	590	1064	optical glass	40.0	0.4	0.71	infinity	infinity	6.0	fused silica	50.7
S6ASS2224	494	671	optical glass	22.0	0.5	0.08	infinity	infinity	-	-	11.6
S6ASS2255	422	-	fused silica	45.0	0.4	0.27	10.0	-	19.1	fused silica	63.4
S6ASS2256	422	-	fused silica	44.9	0.4	0.27	10.0	-	19.1	N-BK7	63.8
S6ASS2258	397	422	optical glass	44.8	0.4	0.28	10.0	10.0	19.1	N-BK7	62.3
S6ASS2258-006	397	422	optical glass	45.5	0.4	0.29	10.0	10.0	6.3	fused silica	60.5
S6ASS2241	395	729	optical glass	66.9	0.3	0.2	20.0	20.0	6.0	fused silica	55.7
S6ASS2241-045	395	729	optical glass	66.9	0.3	0.19	20.0	20.0	6.0	fused silica	55.7
S6ASS2341	370	-	optical glass	82.1	0.2	0.2	6.0	-	6.0	fused silica	55.7
S6ASS2245	369	-	fused silica	40.0	0.4	0.35	infinity	-	8.0	fused silica	39.3
S6ASS2246	369	-	fused silica	41.2	0.4	0.36	infinity	-	4.3	fused silica	38.7
S6ASS2247	369	493	fused silica	50.1	0.2	0.95	8.0	78.0	2.0	sapphire	49.4
S6ASS2247-389	313	397	fused silica	49.0	0.2	0.95	8.2	79.0	2.0	sapphire	48.2
S6ASS2248	313	397	fused silica	49.0	0.3	0.27	15.0	145.0	3.0	fused silica	46.5

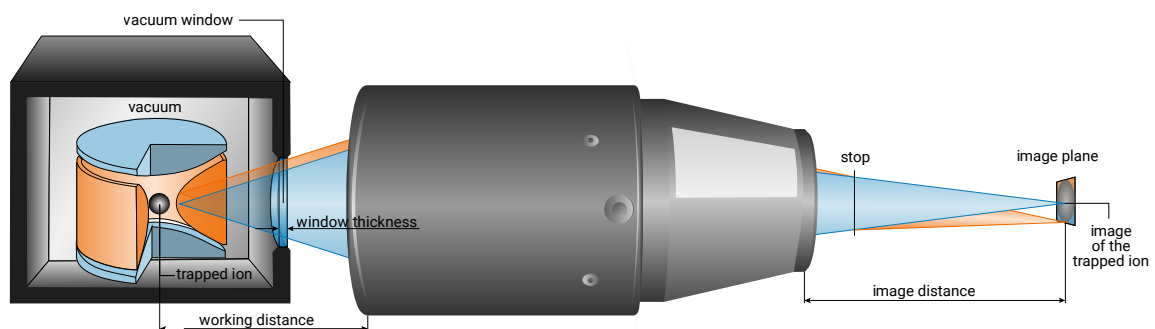

In case of deviations from the portfolio and delivery times, please contact our Customer Care Team.

1. FOCUSING LENSES

1.1 CALCULATION OF THE MINIMUM FOCAL DIAMETER

$$d_F = \frac{\lambda \cdot f' \cdot APO \cdot M^2}{d_L}$$

$$T = \frac{d_L}{d_{EP}}$$

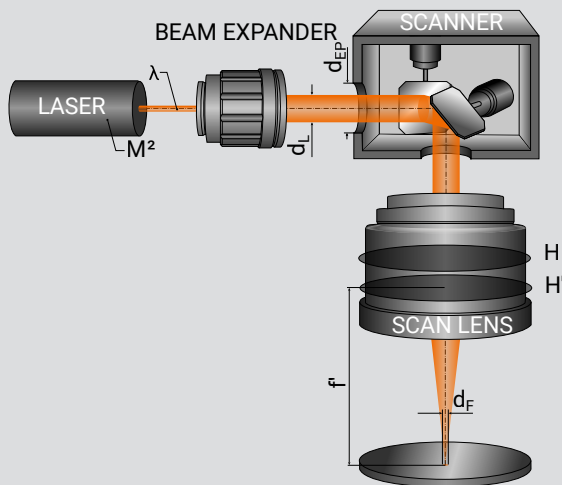
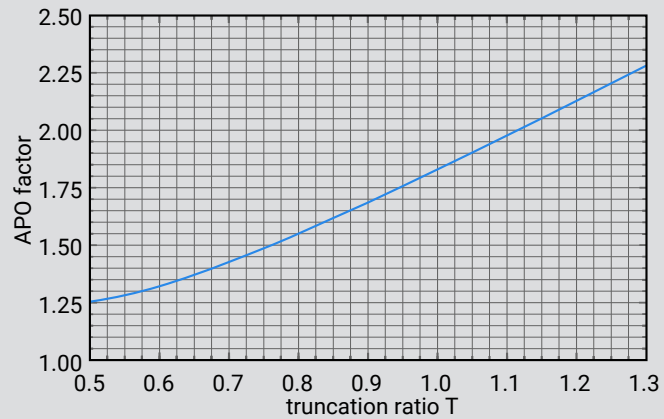

- d_F : focal spot diameter
- d_{EP} : entrance pupil of the scanner
- d_L : entrance beam diameter ($1/e^2$)
- f' : focal length
- λ : wavelength
- APO: apodisation factor
- M^2 : diffraction value of the laser
- T: truncation ratio

1.2 CALCULATION OF THE RAYLEIGH LENGTH

$$z_R = \pi \cdot \left(\frac{d_F}{2}\right)^2 \cdot \frac{(APO/1.27)^2}{\lambda \cdot M^2}$$

z_R : rayleigh length

1.3 CALCULATION OF THE FOCAL DIAMETER FOR FIBER IMAGING

$$d_F = M \cdot d_{fc} \approx \frac{f_2}{f_1} \cdot d_{fc}$$

$$d_{coll} = 2 \cdot f_1 \cdot \tan(\alpha)$$

$$M = \frac{NA_{fiber}}{NA_{focus}}$$

$$\alpha = \sin^{-1}(NA_{fiber})$$

$$NA_{focus} = \sin\left[\tan^{-1}\left(\frac{d_{coll}/2}{f_2}\right)\right]$$

$$\alpha = \tan^{-1}\left(\frac{d_{coll}}{2 \cdot f_1}\right)$$

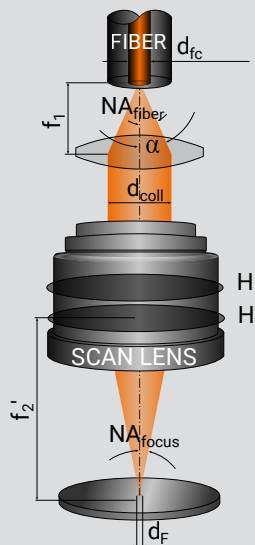

- d_{fc} : fiber core diameter
- NA_{fiber} : numerical aperture of the fiber
- α : half beam cone angle
- M : magnification by NA calculation
- d_F : focal spot diameter
- f_1 : focal length of the collimating lens
- f_2 : focal length of the focussing lens

2. LASER INDUCED DAMAGE THRESHOLD (LIDT)

2.1 ENERGY- AND POWER DENSITY

$$F \left[\frac{J}{cm^2} \right] = \frac{E[J]}{1/4 \cdot (d_F[cm])^2 \cdot \pi}$$

- F : energy density / fluence
- E : pulse energy
- F : focal spot diameter
- I : power density / irradiance
- P_{peak} : peak power of the laser

$$I \left[\frac{W}{cm^2} \right] = \frac{P_{peak}[W]}{1/4 \cdot (d_F[cm])^2 \cdot \pi}$$

2.2 ESTIMATE OF THE LIDT

$$\frac{E[\text{J}]}{\frac{1}{4} \cdot (d_F[\text{cm}])^2 \cdot \pi} \ll \text{LIDT} \approx$$

$$\approx \frac{\lambda}{\lambda_{\text{spec}}} \cdot \sqrt{\frac{\tau}{\tau_{\text{spec}}}} \cdot \text{LIDT}_{\text{spec}}$$

- E: pulse energy
- d_F : focal spot diameter
- λ : used wavelength
- λ_{spec} : specified wavelength
- τ : pulse duration of the used laser
- τ_{spec} : specified pulse duration
- LIDT: real LIDT
- $\text{LIDT}_{\text{spec}}$: specified LIDT

$$\frac{P_{\text{peak}}[\text{W}]}{\frac{1}{4} \cdot (d_F[\text{cm}])^2 \cdot \pi} \ll \text{LIDT} \approx$$

$$\approx \frac{\lambda}{\lambda_{\text{spec}}} \cdot \sqrt{\frac{\tau}{\tau_{\text{spec}}}} \cdot \text{LIDT}_{\text{spec}}$$

3. BEAM EXPANDERS

3.1 CALCULATION OF THE MAGNIFICATION

$$\beta' = \frac{d_{\text{out}}}{d_{\text{in}}}$$

$$\beta'_{\text{max}} = \frac{d_{\text{scanner}}}{d_{\text{in}}}$$

- β' : magnification
- β'_{max} : maximum magnification
- d_{in} : entrance beam diameter
- d_{out} : outgoing beam diameter
- d_{scanner} : aperture of the scanner

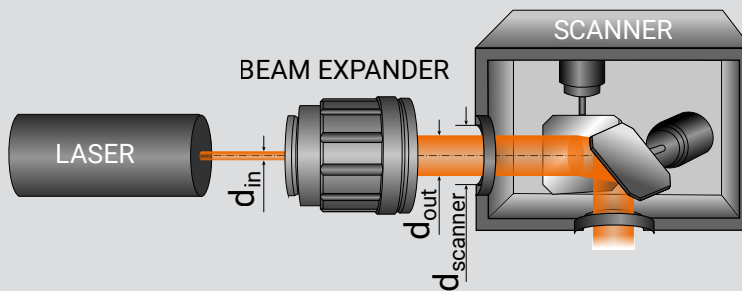

The outgoing beam diameter d_{out} is limited by the beam expander or by the aperture of the scanner.

3.2 DIVERGENCE ANGLE

$$\theta_0 = \frac{\lambda}{\pi \cdot \omega_0/2} \rightarrow \theta_0 \cdot \omega_0 = \text{const}$$

θ_0 : divergence angle
 λ : wavelength
 ω_0 : beam diameter at the waist

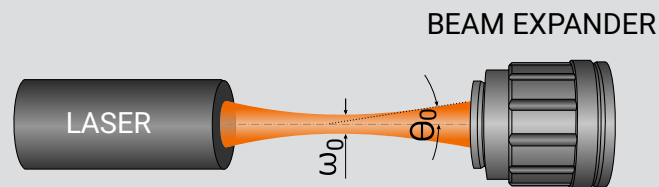

The higher the beam diameter the lower is the divergence!



TELECENTRIC IMAGING LENSES

For nearly 40 years, Sill Optics has been manufacturing **high-end telecentric imaging lenses**. These lenses are specifically designed for measurement applications in industrial machine vision, aiming to eliminate magnification changes and measurement deviations caused by depth of field or defocus.

With the increasing data rates and sensor sizes, there is a clear trend towards larger sensor diagonals and smaller pixel sizes. As a result, our lens portfolio focuses on lenses optimized for small pixel sizes, supporting sensors up to APS format (with sensor diagonal of 32.6 mm).

- Telecentric FOV up to Ø150 mm
- Lens design for R,G,B illumination and monochrome sensor
- Variable iris for improved DOF (depth of focus)
- Available with integrated coaxial illumination upon request

Benefit from our extensive experience and expertise in telecentric imaging lenses. Contact Sill Optics today to discuss your specific requirements and discover the right lens solution for your measurement applications.

PART NUMBER	MAGNIFICATION	RECOMMENDED SENSOR DIAGONAL [mm]	WORKING DISTANCE [mm]	WAVELENGTH BAND MONO (RED, GREEN, BLUE) WHITE (COLOR/BAYER) NIR (800-900 nm)	RECOMMENDED PIXEL SIZE [µm]	THREAD	PART NUMBER FOR VERSION WITH INTEGR. COAXIAL ILLUMINATION
LENSES FOR 1/3" AND 1/2" SENSORS							
S5LPJ1823	0.044	6.0	300.0	R,G,B,NIR	2.20	C	S5LPL1823-LED
S5LPJ1514	0.054	6.0	284.0	R,G,B	2.20	C	S5LPL1514-LED
S5LPJ1824	0.056	8.0	300.0	R,G,B	2.20	C	S5LPL1824-LED
S5LPJ1522	0.068	8.0	284.0	R,G,B	2.20	C	S5LPL1522-LED
S5LPJ6014	0.079	6.0	180.0	R,G,B	2.00	C	S5LPL6014-LED
S5LPJ1523	0.082	8.0	284.0	R,G,B	3.45	C	S5LPL1523-LED
S5LPJ6022	0.100	8.0	180.0	R,G,B	2.20	C	S5LPL6022-LED
S5LPJ1224	0.110	6.0	190.0	R,G,B,W,NIR	2.20	C	S5LPL1224-LED
S5LPJ1201	0.132	6.0	190.0	R,G,B,W	2.20	C	S5LPL1201-LED
S5LPJ1223	0.158	8.0	190.0	R,G,B,NIR	2.00	C	S5LPL1223-LED
LENSES FOR 1/1.8" AND 2/3" SENSORS							
S5LPJ1832	0.065	8.9	300.0	R,G,B,NIR	2.00	C	S5LPL1832-LED
S5LPJ1533	0.098	11.0	284.0	R,G,B	2.00	C	S5LPL1533-LED
S5LPJ6024	0.121	8.9	180.0	R,G,B	2.20	C	S5LPL6024-LED
S5LPJ6033	0.145	11.0	180.0	R,G,B	2.50	C	S5LPL6033-LED
S5LPJ5015	0.160	8.9	88.0	R,G,B	2.80	C	S5LPL5015-LED
S5LPJ1299	0.200	11.0	92.0	R,G,B,NIR	2.80	C	S5LPL1299-LED
S5LPJ2298	0.244	11.0	92.0	R,G,B,W	4.60	C	S5LPL2298-LED
S5LPJ1252	0.265	11.0	190.0	R,G,B,W	2.50	C	S5LPL1252-LED
S5LPJ2893	0.292	11.0	92.0	R,G,B,W,NIR	2.50	C	S5LPL2893-LED
LENSES FOR 1" AND 1.1" SENSORS							
S5LPJ1852	0.112	16.0	300.0	R,G,B	2.20	C	S5LPL1852-LED
S5LPJ1860	0.134	17.6	300.0	R,G,B	3.45	C	S5LPL1860-LED
S5LPJ1551	0.165	16.0	284.0	R,G,B	3.45	C	S5LPL1551-LED
S5LPJ1565	0.195	16.0	284.0	R,G,B	4.20	C	S5LPL1565-LED
S5LPJ6050	0.246	16.0	180.0	R,G,B	3.45	C	S5LPL6050-LED
S5LPJ6060	0.292	16.0	180.0	R,G,B	3.45	C	S5LPL6060-LED
S5LPJ1260	0.313	16.0	190.0	R,G,B	4.60	C	S5LPL1260-LED
S5LPJ2499	0.492	17.6	92.0	R,G,B,W,NIR	3.45	C	S5LPL2499-LED
S5LPJ2898	0.581	17.6	92.0	R,G,B,W,NIR	4.60	C	S5LPL2898-LED

PORTFOLIO IMAGING OPTICS

TELECENTRIC IMAGING LENSES



TELECENTRIC IMAGING LENSES FOR SMALLER FOV

- Low cost alternatives for pixel size 3.45 μm
- Lens design for R,G,B illumination and monochrome sensor

PART NUMBER	MAGNIFICATION	RECOMMENDED SENSOR DIAGONAL [mm]	WORKING DISTANCE [mm]	WAVELENGTH BAND MONO (RED, GREEN, BLUE) WHITE (COLOR/BAYER) NIR (800-900 nm)	RECOMMENDED PIXEL SIZE [μm]	THREAD
LENSES FOR 1/3" AND 1/2" SENSORS						
S5LPJ4425	1.000	8.0	107.5	R,G,B	3.45	C
LENSES FOR 1" AND 1.1" SENSORS						
S5LPJ4061-216	0.600	16.0	121.0	R,G,B,W	3.45	C
S5LPJ3208	0.770	16.0	119.5	R,G,B,W	3.45	C



TELECENTRIC IMAGING LENSES WITH COLOR CORRECTION AND NIR USABILITY

- Telecentric FOV up to $\varnothing 120$ mm
- Lens designs for white illumination with Bayer pattern color sensor
- Lens designs for NIR illumination with monochrome sensor
- Variable iris for improved DOF (depth of focus)

PART NUMBER	MAGNIFICATION	RECOMMENDED SENSOR DIAGONAL [mm]	WORKING DISTANCE [mm]	WAVELENGTH BAND MONO (RED, GREEN, BLUE) WHITE (COLOR/BAYER) NIR (800-900 nm)	RECOMMENDED PIXEL SIZE [μm]	THREAD
LENSES FOR 1/3" AND 1/2" SENSORS						
S5LPJ6122	0.100	8.0	180.0	R,G,B,W,NIR	2.00	C
S5LPJ1722	0.068	8.0	284.0	R,G,B,W,NIR	2.00	C
LENSES FOR 1/1.8" AND 2/3" SENSORS						
S5LPJ1733	0.098	11.0	284.0	R,G,B,W,NIR	2.00	C
S5LPJ6133	0.145	11.0	180.0	R,G,B,W,NIR	2.50	C
LENSES FOR 1" AND 1.1" SENSORS						
S5LPJ6150	0.246	17.6	180.0	R,G,B,W,NIR	3.45	C
S5LPJ1750	0.165	17.6	284.0	R,G,B,W,NIR	3.45	C



TELECENTRIC IMAGING LENSES FOR SENSOR SIZE UP TO APS FORMAT

- High performance telecentric lenses for pixel size <math><3.45 \mu\text{m}</math>
- Large sensor diagonal for high resolution C-Mount cameras up to 25 MPx
- Large sensor diagonal for high resolution APS format cameras up to 60 MPx
- Excellent color correction for Bayer pattern color sensors with white illumination
- Excellent performance in NIR with small working distance adjustment

PART NUMBER	MAGNIFICATION	RECOMMENDED SENSOR DIAGONAL [mm]	WORKING DISTANCE [mm]	WAVELENGTH BAND MONO (RED, GREEN, BLUE) WHITE (COLOR/BAYER) NIR (800-900 nm)	RECOMMENDED PIXEL SIZE [μm]	THREAD
LENSES FOR 1.2" AND 1.5" SENSORS						
S5LPJ1862	0.130	19.2	300.0	R,G,B,W,NIR	2.74	C
S5LPJ1762	0.200	19.2	284.0	R,G,B,W,NIR	2.74	C
S5LPJ1762-M42	0.200	24.0	284.0	R,G,B,W,NIR	2.74	M42x1
S5LPJ6162	0.300	19.2	180.0	R,G,B,W,NIR	2.74	C
S5LPJ6162-M42	0.300	24.0	180.0	R,G,B,W,NIR	2.74	M42x1
S5LPJ6405	0.500	19.2	176.0	R,G,B,W,NIR	2.74	C
S5LPJ6406	0.600	22.0	155.0	R,G,B,W,NIR	2.74	C
S5LPJ6407	0.700	22.0	140.0	R,G,B,W,NIR	2.74	C
S5LPJ6408	0.800	22.0	131.0	R,G,B,W,NIR	2.74	C
S5LPJ6409	0.900	19.2	127.0	R,G,B,W,NIR	2.74	C
S5LPJ7201	1.000	21.4	81.0	R,G,B,W,NIR	2.74	C
S5LPJ6415	1.500	21.4	80.2	R,G,B,W	2.40	C
S5LPJ6420	2.000	21.4	68.1	R,G,B,W	2.74	C
S5LPJ6425	2.500	19.2	61.4	R,G,B,W	3.10	C
S5LPJ6430	3.000	19.2	57.0	R,G,B,W	3.45	C
LENSES FOR APS FORMAT SENSORS						
S5LPJ1894-FM0	0.200	28.2	300.0	R,G,B,W,NIR	2.74	F
S5LPJ1894-M42	0.200	28.2	300.0	R,G,B,W,NIR	2.74	M42x1
S5LPJ1794-FM0	0.310	32.6	284.0	R,G,B,W,NIR	2.74	F
S5LPJ1794-M42	0.310	32.6	284.0	R,G,B,W,NIR	2.74	M42x1
S5LPJ6194-FM0	0.450	32.6	180.0	R,G,B,W,NIR	2.74	F
S5LPJ6194-M42	0.450	32.6	180.0	R,G,B,W,NIR	2.74	M42x1
S5LPJ2607-FM0	0.710	35.0	140.0	R,G,B,W,NIR	2.74	F
S5LPJ2607-M42	0.710	35.0	140.0	R,G,B,W,NIR	2.74	M42x1
S5LPJ7201-FM0	1.000	32.6	81.0	R,G,B,W,NIR	2.74	F
S5LPJ7201-M42	1.000	32.6	81.0	R,G,B,W,NIR	2.74	M42x1

PORTFOLIO IMAGING OPTICS

TELECENTRIC IMAGING LENSES



TELECENTRIC LENSES WITH INTEGRATED TUNABLE LIQUID LENS

- High performance stability within specified tuning range.
- Constant telecentricity, small linear magnification change within tuning
- Good color correction and performance stability for 1.2" magnifying lenses in vertical orientation (gravity influence on liquid reduces performance in horizontal orientation)
- Good performance stability in both vertical and horizontal orientation for 1" demagnifying lenses.

PART NUMBER	MAGNIFICATION	RECOMMENDED SENSOR DIAGONAL [mm]	WORKING DISTANCE [mm]	TUNING RANGE [mm]	WAVELENGTH BAND MONO (RED, GREEN, BLUE) WHITE (COLOR/BAYER) NIR (800-900 nm)	RECOMMENDED PIXEL SIZE [µm]	THREAD	PART NUMBER FOR VERSION WITH INTEGR. COAXIAL ILLUMINATION
S5VPJ1565	0.193	16.0	284.0	+/-70.0	R,G,B	2.74	C	-
S5VPJ6060	0.289	16.0	180.0	+/-32.5	R,G,B	2.74	C	S5VPL6060-LED
S5VPJ1260	0.311	16.0	190.0	+/-27.5	R,G,B	3.10	C	-
S5VPJ2898	0.578	16.0	92.0	+/-8.5	R,G,B	3.10	C	S5VPL2898-LED
S5VPJ6415	1.500	19.2	80.2	+/-5	R,G,B,W	2.74	C	-
S5VPJ6420	2.000	19.2	68.2	+/-5	R,G,B,W	2.74	C	-
S5VPJ6425	2.500	19.2	61.4	+/-5	R,G,B,W	3.10	C	-



Besides our portfolio telecentric lenses, we also offer a variety of **telecentric and entocentric designs upon request**.

These special lenses are not manufactured regularly. We kindly ask you to send us your inquiry to check availability, lead time and price according your required quantity.

To enable a short lead-time for your test setup, we are going to build up a demo lens stock.

PART NUMBER	MAGNIFICATION	RECOMMENDED SENSOR DIAGONAL [mm]	WORKING DISTANCE [mm]	WAVELENGTH BAND MONO (RED, GREEN, BLUE) WHITE (COLOR/BAYER) NIR (800-900nm) SWIR (900-1700nm)	RECOMMENDED PIXEL SIZE [µm]	THREAD
TELECENTRIC LENSES FOR APS FORMAT SENSORS						
S5LPJ0492-M42	2.00	35.0	96.5	R,G,B,W	4.60	M42x1
TELECENTRIC LENSES FOR FULL FORMAT AND LARGER SENSORS						
S5LPJ3025-M58	0.25	43.3	310.0	R,G,B,W	3.45	M58x0.75
S5LPJ3005-M72	0.33	60.0	310.0	R,G,B	3.45	M72x0.75
S5LPJ1556-M58	0.46	43.3	332.3	R,G,B,W,NIR	3.30	M58x0.75
S5LPJ7207-M72	0.66	43.3	180.0	R,G,B	5.50	M72x0.75
S5LPJ7209-M72	0.80	43.3	180.0	R,G,B	4.00	M72x0.75
S5LPJ7255-M72	1.00	56.0	120.0	R,G,B	4.60	M72x0.75
S5LPJ7211-M90	1.00	70.0	180.0	R,G,B	5.00	M90x1
S5LPJ7212-M90	1.25	70.0	141.0	R,G,B	4.20	M90x1
S5LPJ7215-M90	1.51	70.0	111.0	R,G,B	6.00	M90x1
HIGH-MAGNIFICATION TELECENTRIC LENSES						
S5LPJ2533	3.00	16.0	100.4	R	3.45	C
S5LPJ2555	5.00	16.0	100.5	R	4.50	C
TELECENTRIC SWIR LENSES						
S5LPJ6835	0.33	16.0	147.0	SWIR	10.00	C
S5LPJ6837	0.50	24.0	147.0	SWIR	10.00	M42x1

PART NUMBER	FOCAL LENGTH [mm]	RECOMMENDED SENSOR DIAGONAL [mm]	MINIMUM F#	WORKING DISTANCE RANGE [mm]	WAVELENGTH BAND MONO (RED, GREEN, BLUE) WHITE (COLOR/BAYER) NIR (800-900nm) SWIR (900-1700nm)	RECOMMENDED PIXEL SIZE [µm]	THREAD
ENTOCENTRIC SWIR LENSES							
S5LPJ6805-216	50.0	16.0	1.8	400 - inf	SWIR	10.00	C
S5LPJ6807-M42	75.0	25.6	2.0	500 - inf	SWIR	10.00	M42x1
ENTOCENTRIC TELE LENSES FOR LASER PROCESS IMAGING							
S5LPJ0305	150.3	8.0	8.0	infinity	R	5.60	C
S5LPJ0303	305.3	11.0	16.0	infinity	R	5.00	C
ENTOCENTRIC TELE LENSES FOR LASER PROCESS IMAGING WITH INTEGRATED LIQUID LENS							
S5VPJ0305	150.0	11.0	8.0	infinity	R	5.60	C
S5VPJ0303	304.3	11.0	11.0	infinity	R	5.00	C

PORTFOLIO IMAGING OPTICS

LED CONDENSERS & ACCESSORY



Within our telecentric imaging lens portfolio, we have also developed LED condensers that complement our offerings. These condensers serve as collimated backlights for high-precision measurements in machine vision applications. Our main expertise lies in optical subassemblies that ensure the emitted light exhibits high homogeneity and parallelism.

In addition to the condensers available in our portfolio, we can provide other sizes (up to an illumination diameter of Ø150) and offer modifications or custom developments upon request. We are committed to meet your specific requirements and providing tailored solutions for your imaging needs.

PART NUMBER	CLEAR APERTURE/ ILLUMINATION DIAMETER [mm]	FOCAL LENGTH [mm]	LED	WAVELENGTH [nm]	MAX. CURRENT [mA]	CONNECTOR
IR CONDENSER						
S6IRI4530	30.0	30.0	SFH4770S	850	1000	M8 / 4-pin
S6IRI4540	55.0	76.0	SFH4770S	850	1000	M8 / 4-pin
S6IRI4550	73.0	100.0	SFH4770S	850	1000	M8 / 4-pin
RED CONDENSER						
S6IRI4531	30.0	30.0	GR QSSPA1.13	623	1000	M8 / 4-pin
S6IRI4541	55.0	76.0	GR QSSPA1.13	623	1000	M8 / 4-pin
S6IRI4551	73.0	100.0	GR QSSPA1.13	623	1000	M8 / 4-pin
BLUE CONDENSER						
S6IRI4532	30.0	30.0	GB QSSPA1.13	470	1000	M8 / 4-pin
S6IRI4542	55.0	76.0	GB QSSPA1.13	470	1000	M8 / 4-pin
S6IRI4552	73.0	100.0	GB QSSPA1.13	470	1000	M8 / 4-pin
GREEN CONDENSER						
S6IRI4533	30.0	30.0	GT QSSPA1.13	528	1000	M8 / 4-pin
S6IRI4543	55.0	76.0	GT QSSPA1.13	528	1000	M8 / 4-pin
S6IRI4553	73.0	100.0	GT QSSPA1.13	528	1000	M8 / 4-pin

ACCESSORY FOR TELECENTRIC IMAGING LENSES AND LED CONDENSERS

PART NUMBER	DESCRIPTION
LENS MOUNT SET	
S5SET0020	Clamping Ø60/Ø75 for many telecentric lenses
S5SET0022	Clamping Ø47 for all LED condensers
BEAMS SPLITTER CUBES FOR INTEGRATED COAXIAL ILLUMINATION	
S0SET9125-000	Polarized beam splitter (standard condition)
S0SET9125-017	Non-polarized beam splitter
RETARDATION PLATES FOR INTEGRATED COAXIAL ILLUMINATION	
S5SET1150	half wave plate for 630nm, slide-in unit
S5SET8325-040	half wave plate for 630nm, add-on unit
USB DRIVER FOR FOCUS TUNABLE OPTOTUNE LENSES	
S5ZUB1640	Optotune USB Driver EL-E-4i
S5ZUB1641	Hirose 6-pin connection cable for USB Driver EL-E-4i

Other accessory upon request.

In case of demands on modifications, please contact our Customer Care Team.

LENS DESIGNS – TELECENTRIC LENSES

OBJECT-SIDED TELECENTRIC LENS

Object-sided telecentric lenses offer the highest measurement precision because the chief rays in the object space are parallel, and there is no magnification change with variations in working distance within the depth of field.

In addition to our portfolio of telecentric lenses, Sill Optics has successfully developed numerous customized telecentric designs for series production.

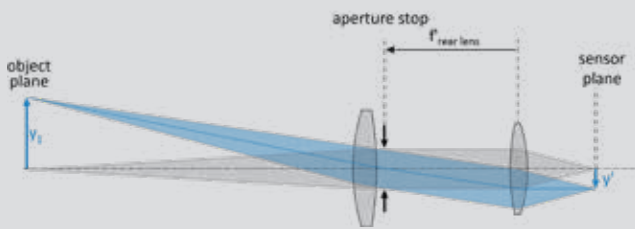
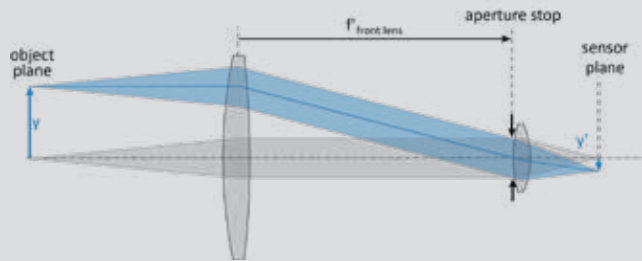

IMAGE-SIDED TELECENTRIC LENS

Image-sided telecentric lenses are essential for various specialized imaging purposes or specific camera types. These lenses are specifically designed for applications where intermediate images are required for follow-up systems (e.g., spectrometers) or for prism-based three-chip sensors.

In many applications with CMOS sensors, a small angle of incidence at the sensor side is adequate for optimal performance.

BI-TELECENTRIC LENS

Bi-telecentric lenses integrate both object-sided and image-sided telecentric beam paths into a single lens. These lenses offer significant advantages for high-spec imaging applications and provide minimal distortion.

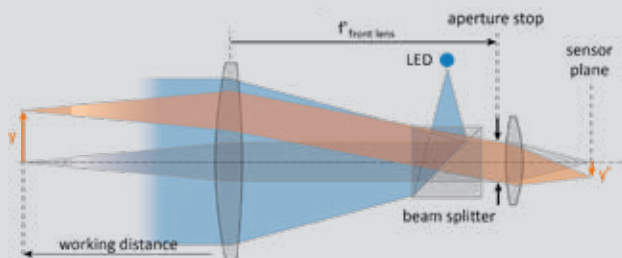
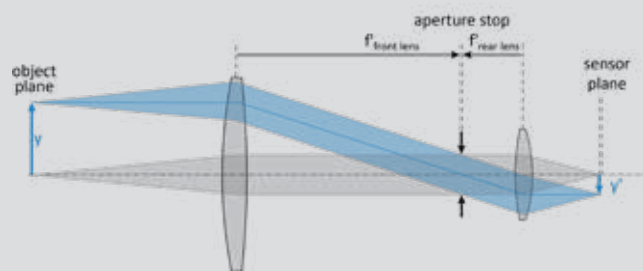

TELECENTRIC LENS WITH INTEGRATED COAXIAL ILLUMINATION

Telecentric lenses with integrated coaxial illumination offer a unique combination of telecentric imaging and coaxial collimated front illumination. This design incorporates a beam splitter to introduce the illumination path, while the front part of the telecentric lens collimates the light.

LENS DESIGNS – TELECENTRIC LENSES

MICROSCOPE LENSES

Sill Optics is no typical microscope lens manufacturer for standards with small field of view (FOV) and high NA.

Nevertheless, we have the manufacturing expertise to realize microscope lenses for applications with larger working distance (≥ 5 mm) and $NA \leq 0.5$ that require larger FOV or special waveband correction.

We are your trusted partner in finding customized solutions to meet your individual requirements.

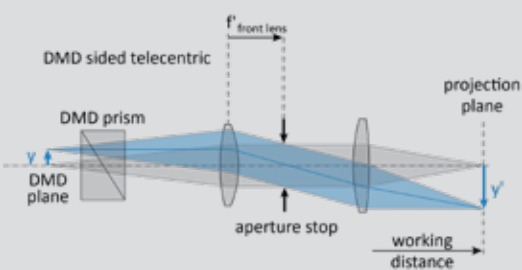
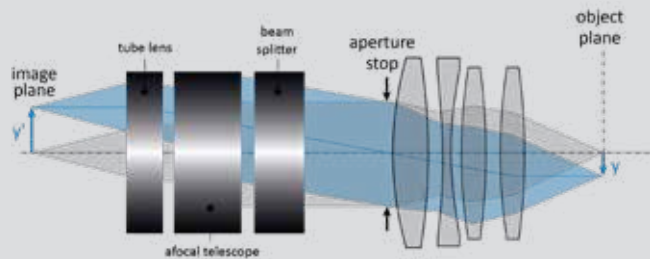

DMD LENSES

DMD lenses are specifically designed for the projection of a digital micromirror device. These lenses feature a telecentric design on the DMD side. When working with DMDs, it is essential to consider the prism material and internal distances to prevent axial color shift.

At Sill Optics, we are your trusted partner, especially when it comes to lenses for DMD manufacturing and precision measurement pattern projection. Our expertise in this area ensures that we can provide you with the optimal lens solutions tailored to your specific needs.

TELECENTRIC LENSES WITH INTEGRATED TUNABLE LIQUID LENS

Telecentric lenses with integrated tunable liquid lenses provide the capability for fast focus changes without the need for moving elements. While we offer a range of telecentric lenses in our portfolio, our true strength lies in designing custom lenses with integrated liquid lenses.

In our projects, we typically incorporate liquid lenses from Optotune, as we have had positive experiences with their reliable products.

However, it is worth noting that we can also develop entocentric designs with integrated lenses if needed.

Count on Sill Optics to deliver the precise lens solution with integrated tunable liquid lenses that meets your specific requirements.

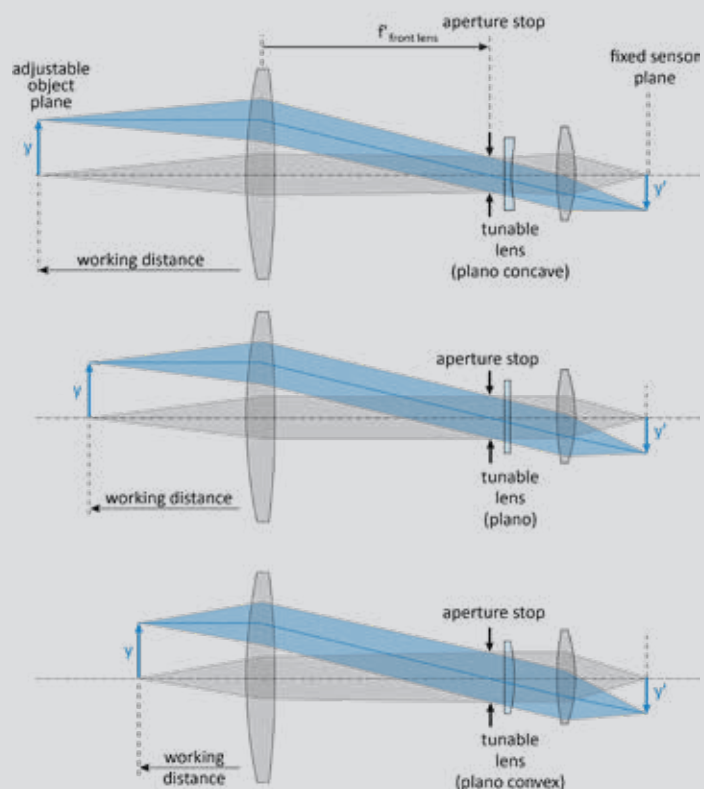

LENS DESIGNS - ENTOCENTRIC LENSES

LARGE FIELD ENTOCENTRIC LENS

Sill Optics defines "large field" as referring to lenses designed for use with sensors of a large diagonal size. When dealing with line scan cameras or large format area sensors with a length or diagonal size exceeding 43.3mm (full format), the complexity of entocentric lens design increases. These scenarios create a demand for custom development, particularly when high aperture, high resolution, and/or large bandwidth are required.

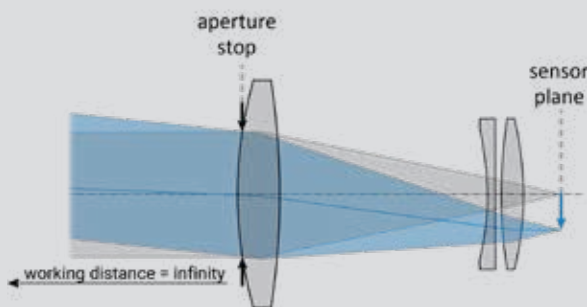
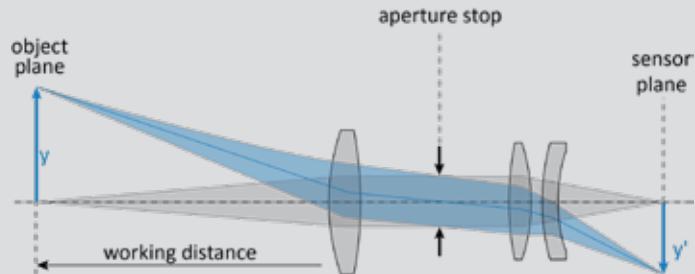

TELEPHOTO LENS

Telephoto lenses are characterized by their long focal length, which is typically greater than their physical length. These lenses are designed to capture images of distant objects with a specific magnification factor.

In telephoto lenses, the aperture stop is typically positioned at the front surface of the lens. When a larger aperture is desired, a correspondingly large front lens element is necessary to accommodate it.

WIDE-ANGLE LENS

Wide-angle lenses are commonly used for observation applications or imaging tasks that require capturing a large field of view at significant distances.

These lenses can be designed in two main configurations: fisheye lenses, which feature concave lens elements at the front, as shown; or pinhole lenses, where the aperture is positioned outside the lens assembly.

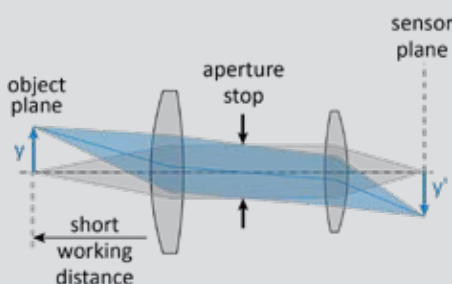
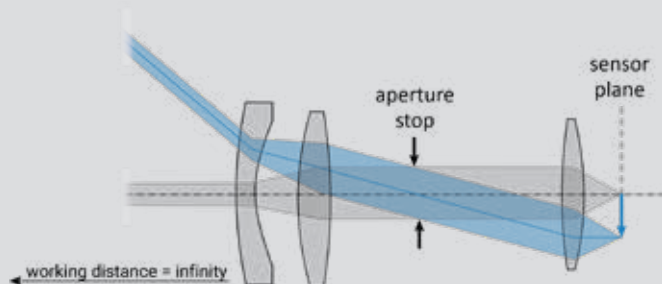

MACRO LENS

Macro lenses are entocentric lenses designed for capturing close-up shots with magnifications ranging from approximately 0.5x to 1.5x. These lenses feature a small optical transfer length and typically have a large aperture.

Due to the short transfer length, macro lenses require a short focal length and must be carefully designed to fit within the available space without compromising performance.

LENS DESIGNS - ENTOCENTRIC LENSES

RELAY LENS

Relay lenses are integral components of optical systems used to transfer an intermediate image plane to the pupil plane (Fourier plane) and/or back to a final image plane. They play a crucial role in various applications, such as refractive spectrometers.

Relay systems can be designed in a symmetric configuration, where the magnification is 1:1, or in an asymmetric configuration with a magnification ratio of 1:X. The choice of configuration depends on the specific requirements of the optical system.

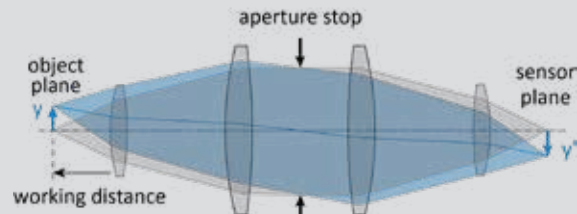

Furthermore, relay lenses can also be utilized for pupil relays in specialized scanning setups. These setups allow for precise scanning and control of the beam path.

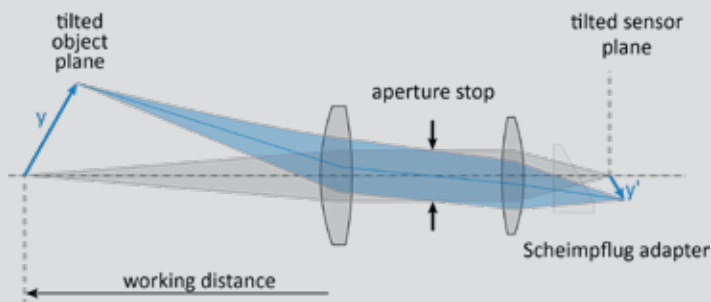

SCHEIMPFLUG LENS FOR TILTED OBJECT PLANE

Scheimpflug lenses are designed to image a tilted object plane onto a tilted image plane while minimizing critical blur. This allows for capturing accurate measurements even when dealing with non-planar objects. The distortion can also be optimized for specific measurement purposes.

To accommodate standard imaging cameras, a tilting adapter can be used to meet the imaging performance requirements. This adapter ensures that the Scheimpflug imaging setup is compatible with the camera system being used.



Laser specifications
(pulse duration, wavelength,
1/e² beam diameter, pulse energy,
M²)

Scanner data
(free aperture, mirror positions,
distance to scan lens)

Scan lens requirements
(telecentricity, scan field, focal
length, spot diameter, entrance
beam diameter)

Beam expander requirements
(magnification (region), wavelength,
motorized, entrance beam diameter)

Trapped Ion lens data
NA, vacuum window data (thickness,
material, position), wavelengths,
magnification, scan field)

Field size (FOV, sensor size)

Camera specifications
(sensor dimensions, pixel size, reso-
lution, camera thread, back flange
distance,
maximum chief ray angle, color)

Aperture

Waveband
(UV, VIS, IR, bandwidth)

Space constraints
(total track, working distance,
maximum length, maximum diameter,
mounting)

Performance requirements
(Strehl ratio, MTF, edge spread
function, distortion, color correction)

NOTES

FOR YOUR INDIVIDUAL PROJECT

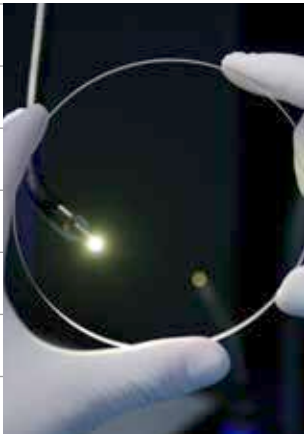



Jürgen Stollhof
Director Sales & Marketing



Dr. Christoph Horneber
Director Research & Development



Stefan Uwe Best
Key Account Manager



Markus Klahr
Manager Internal Sales



Sabrina Rienesl
Customer Care



Sara Hildebrandt
Customer Care



Sabine Epner
Customer Care



Manuel Zenz
Project Management



Julian Perlitz
Project Management



Andreas Platz
Project Management



Katharina Konerth
Project Management



Thomas Schuffenhauer
Project Management



Dr. Jonas Herbst
Project Management



Cornelia Halbhuber
Project Management



Raphaela Streit
Project Management



Michail Kromm
Project Management

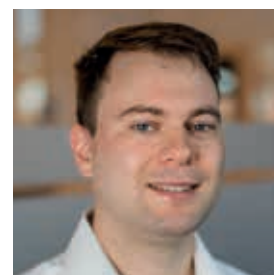

Martin Kolb
Product Management

Sill Optics GmbH
Johann-Höllfritsch-Str. 13
90530 Wendelstein
Germany



WWW.SILLOPTICS.DE